

Elegance and Strength

**BBR HiAm CONA**

Strand Stay Cable Damping Systems

**BBR** A Global Network of Experts  
[www.bbrnetwork.com](http://www.bbrnetwork.com)



# Cable vibration and damping

Despite the wide use of cable-stayed bridges, there are still several areas of great concern, especially the effects and elimination of cable vibration phenomena.

Even newly constructed cable-stayed bridges have experienced quite severe vibrations.

Several cable vibration mechanisms have been identified and characterized, with the four most common phenomena being vortex shedding, galloping, parametric excitation (deck/pylon and cable interaction) and rain-wind induced vibrations. The short-term

consequence of cable vibration is complaints from the public (bridge users) the long-term consequences are reduced safety or even failure of complete cables caused by a rapid accumulation of bending fatigue stress cycles at the anchorages.

## Inherent damping

Structural elements have a certain level of inherent "self" damping,  $\delta_i$ , which conservatively, for strand stay cables can be assumed as 0.8% logarithmic decrement. The inherent damping of a stay cable is the maximum rate at which the cable dissipates the energy which makes it oscillate. Often the inherent damping is not sufficient to damp the stay cable and then it is necessary to add passive supplemental damping. Additionally to the supplemental damping, the installation of special measures, like surface treatment of the cable and cross-ties, might reduce the Required Supplemental Damping,  $\delta_{Req.Sup}$ , and hence improve the response of the stay cable against vibrations.



## Specification

The Required Supplemental Damping should be specified by the designer for a particular stay cable arrangement, stay pipe configuration (diameter, with or without surface treatment) and stay cable mass. The inherent damping of the particular configuration needs then to be deducted. A sufficient factor of safety, SF, in the order of load factors applied in structural engineering, must be achieved between the Required Supplemental Damping and the Maximum Theoretical Supplemental Damping:

$$\delta_{Req.Sup} = 2 \cdot \pi \cdot \frac{S_c \cdot \rho_a \cdot D_s^2}{m_s} - \delta_i \leq S_F \cdot \delta_{Max.Sup}$$

$$\text{where } \delta_{Max.Sup} \approx \pi \cdot \frac{L_d}{L_s}$$

Where,  $S_c$  is the Scruton Number,  $\rho_a$  [1.25 kg/m<sup>3</sup>] is the density of the air,  $D_s$  [m] is the outer diameter of the stay cable,  $m_s$  [kg/m] is the linear mass of the stay cable,  $L_d$  [m] the distance from the anchorage to the damper and  $L_s$  [m] the length of the stay cable.

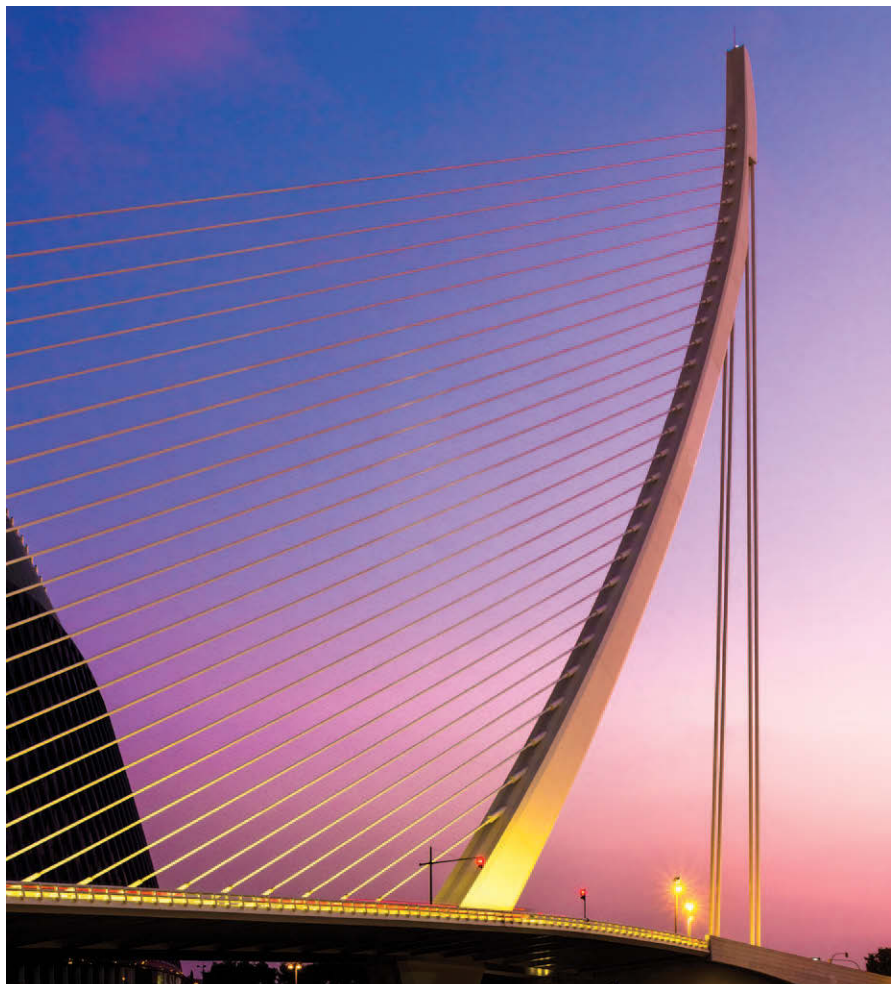

# Supplemental damping

Along each oscillation a small portion of the energy stored through the stay cable length is lost due to friction phenomena near anchorages. Occasionally the rate at which this energy is lost is very scanty (i.e. low inherent damping) leading to large amplitudes and large number of oscillations. In these scenarios damping devices increase the energy lost per cycle and reduce the free oscillating time.

The maximum supplemental damping that a perfect damper could provide to a cable (i.e. efficiency of the damper is not considered)

solely depends on the relative location of the damper along the cable,  $L_D/L_S$ , and is independent of the nature of the damper (friction, viscous, gas, etc.). In general, dampers are normally installed in medium to long cables ( $L_S \neq 80$  m) at a distance  $\sim 2.5\%$  of the cable length, therefore specific provisions should be made by the designer at an early stage.

Active damping devices are also available, but they require external power sources and high maintenance and should therefore only be considered for repairs and retrofits.



## Installation

Dampers are usually installed once stay cables are structurally active and carry the permanent and superimposed loads of the structure. After installation, factors such as service loads, traffic, wind and temperature modify the geometry of the entire structure and consequently induce relative rotations between the structure and the stay cable, which result in transversal and longitudinal movements at the damper location. These movements are often larger than those imposed on the damper and on the anchorages by possible cable vibrations. To ensure good damping performance, durability and safety, the damper, stay cables and the anchorages must be seen as an integrated system which has to be analyzed, designed and detailed as a whole. Consequently, both the stay cable and the damping device should be provided by the same company.



# Countering cable vibration

A preliminary evaluation of the susceptibility of a stay cable to vibration can be performed using the Scruton Number which is a measure of the aerodynamic stability of the cable. In general, it is recommended that the Scruton Number is kept as high as possible and values greater than 10 are often suggested.

Over the years BBR Headquarters has built an extensive knowledge of all these special stay cable phenomena which has led to a wide and comprehensive documentation and to robust and reliable proprietary software tools that allow for a safe, detailed and precise analysis. Among other subjects,

BBR provides technical support to stay cable projects on the following:

- An early and precise evaluation of the actual inherent damping for a particular stay cable configuration might avoid the installation of damper devices leading to considerable cost savings.
- Some complex vibration phenomena such as ice-galloping, dry galloping and den Hartog galloping on temporary stay cable are not covered by considering standard  $S_c$  values and should be specifically analyzed for each particular project.
- Long cables oscillating under symmetric vibration modes (i.e. 1<sup>st</sup>, 3<sup>rd</sup>, etc.) are proven to exhibit regions of reduced

movement near the anchorages which decreases the actual supplemental damping provided by a damper device. In these scenarios, longer  $L_D$  distances are needed. BBR provides accurate analysis leading to the precise location of the damper device without over-estimating  $L_D$  that increases costs and harms the bridge aesthetics.

- Dampers must be correctly fine-tuned in order that they provide the best possible performance under the most common vibration modes (i.e. 1<sup>st</sup> and 2<sup>nd</sup> vibration modes).



# Reducing supplemental damping



BBR offers an effective countermeasure against rain-wind induced vibrations by equipping the outside cable surface with a helical rib. The helical fillet helps to prevent the formation of the coherent upper water rivulets, which are responsible for the cable vibrations and therefore mitigates the excitation at its source. Using BBR Strand Stay Pipes with helical rib, the minimum required Scruton Number to prevent rain-wind cable vibration may be reduced to a value as low as 5. Supplemental damping can further be reduced by choosing a Compact BBR Strand Stay Pipe.

# BBR Square Damper

The BBR Square Damper is a superior supplemental passive damping device, which is based on friction. The device can be used as an internal damper, where it is installed inside the steel guide pipe or alternatively as an external damper, attached to the cable free length using a damper housing and external brace. If the transversal force on the cable at the damper location exceeds the static friction force of the damper, the damper begins to move with the cable and dissipates energy leading to the damping of the cable.

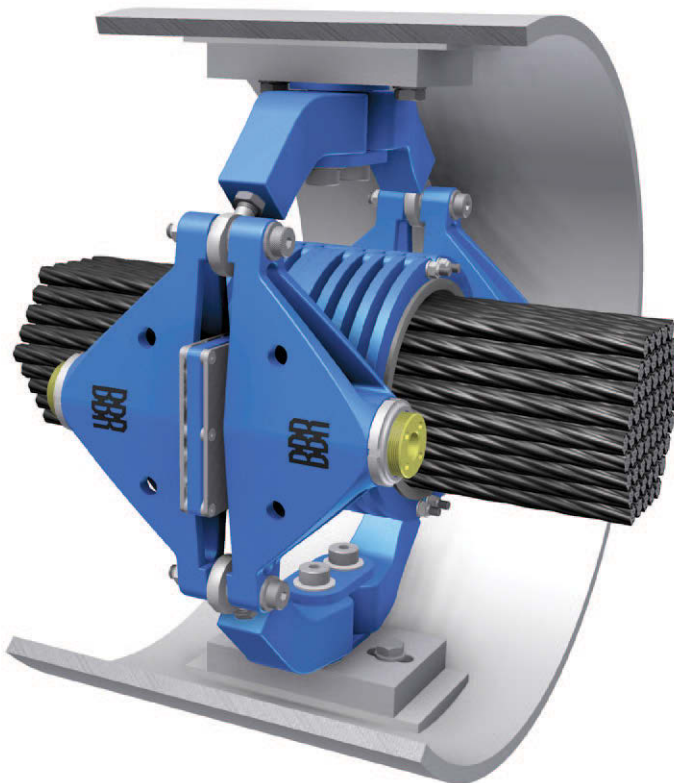
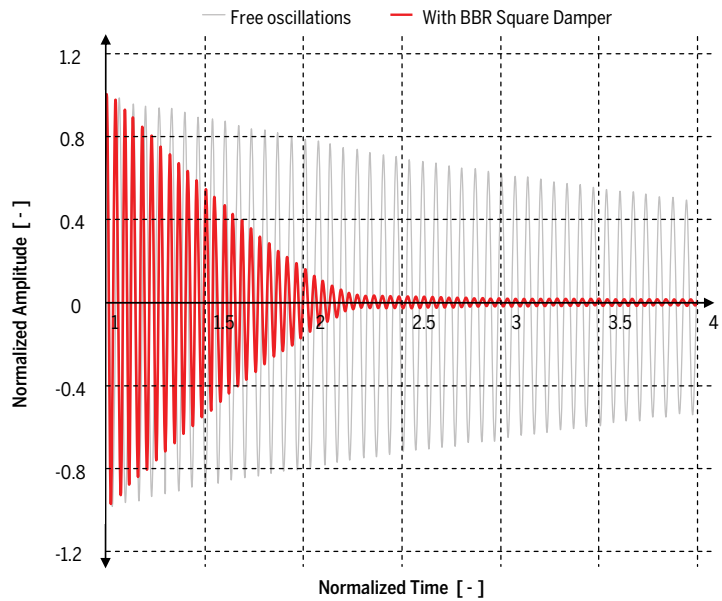

The basic characteristics of the BBR Square Damper are:

- The damper is not activated at low and non-critical cable vibration amplitudes, avoiding constant working of the damper and minimizing maintenance requirements.
- The damping efficiency is independent of the acceleration and mode of cable vibration.
- The damper has been proven, by testing, to achieve the Maximum Passive Supplemental Damping considered for a 'perfect damper' and thus the safety factors relating to Required Supplemental Damping can be reduced.
- Free longitudinal movement and free rotation of the stay cable at the damper location is provided, allowing for temperature elongation and force variations of the stay cable without constraints.
- The damper can easily be fine tuned at any time.
- The friction parts ensure uniform friction properties and extremely low maintenance.
- Due to its simple design, high efficiency, easy adjustability and low maintenance requirements, the BBR Square Damper is superior compared to other damping devices.

BBR also offers a selection of other vibration counter-measures, upon request, for particular projects.



# New generation materials

The development of the BBR Square Damper has included, among others, several multi-million cycles of full damper oscillation wear tests to establish the actual endurance of the friction components. During the tests the temperature was deliberately kept constantly high ( $T > 300\text{ }^{\circ}\text{C}$ ) to promote wear and damage. Such tests proved that

only a new generation of friction materials, especially designed for the severity of this applications, can be used.

The BBR Square Damper incorporates this new generation of friction materials, together with a ventilation/insulation system to enhance the durability of the components and to extend maintenance intervals.



## R&D on extra long cables

The BBR Square Damper has been extensively tested on multiple cable configurations, including normal and shallow cables. The Maximum Passive Supplemental Damping of each specific configuration for 1<sup>st</sup> to 4<sup>th</sup> mode was always achieved – even in tests on shallow cables with equivalent lengths up to 500 m.

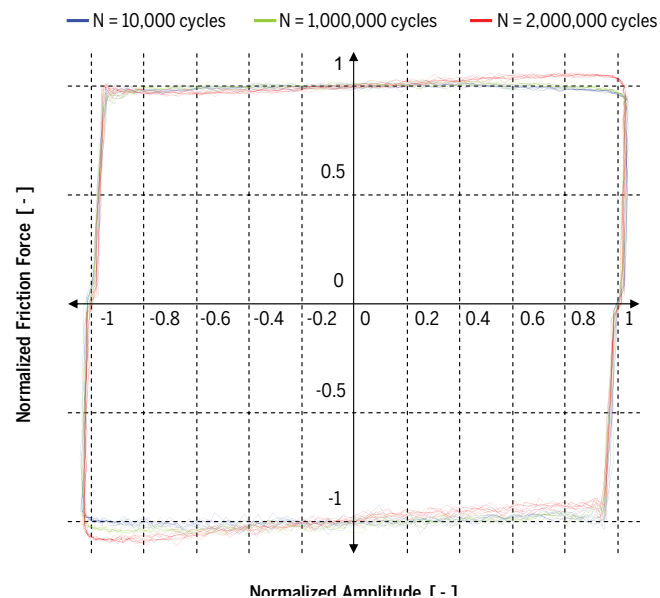

# BBR Viscous Damper

The BBR Viscous Damper, specially developed to counteract vibrations on stay cables, works based on the resistance induced by the rapid passage of a viscous fluid through a narrow opening. The resistance can dissipate a large amount of

energy leading to the damping of the cable. This principle of energy dissipation allows an independent and real-time reaction of the damping device to the occurring vibrations. The BBR Viscous Damper consists of twin hydraulic telescopic cylinders. The inner

cylinder has the piston working chambers and the outer cylinder works as a housing and reservoir. The BBR Viscous Damper can be installed in either an internal or external damper configuration.



## Internal viscous damper

The internal viscous damper is mounted inside a steel housing which gives support and protects against the environment. This compact solution is often preferred because it has a more pleasing design from an aesthetical point of view.

The standard BBR Viscous Damper (internal) is a double acting device and available for a maximum damping force of up to 50 kN. Larger damping force resistance is available upon request.

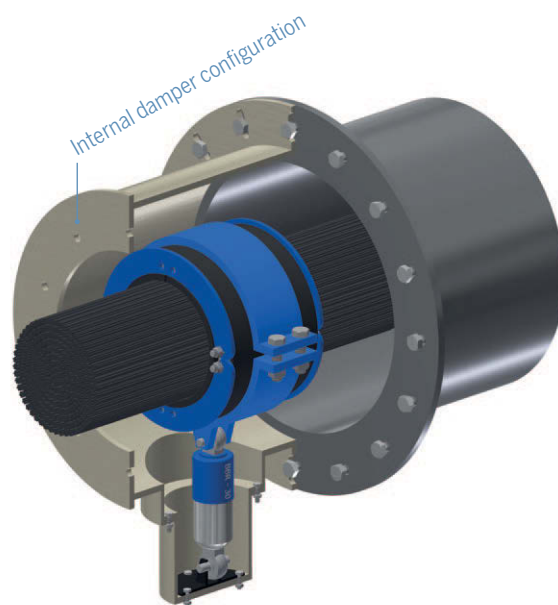

## External viscous damper

The external viscous damper connects the stay cable directly to the deck without a damper housing. The BBR Viscous Damper (external) is equipped with a superior surface protection coating which protects it from the environment. The standard external damper is a double acting device, extension and compression, and is available for a maximum damping force of up to 70 kN. Larger damping force resistance is available upon request.

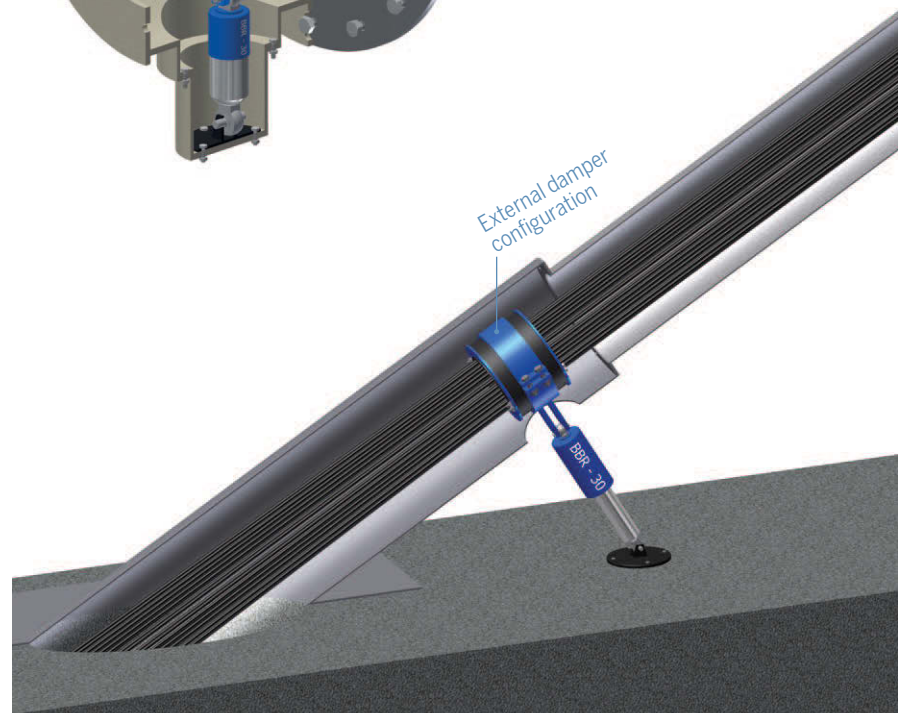





**BBR VT International Ltd**  
Ringstrasse 2  
8603 Schwerzenbach (ZH)  
Switzerland

Tel +41 44 806 80 60  
Fax +41 44 806 80 50

[www.bbrnetwork.com](http://www.bbrnetwork.com)  
[info@bbrnetwork.com](mailto:info@bbrnetwork.com)

**BBR VT International Ltd**  
Technical Headquarters and Business Development Centre  
Switzerland

*Every effort is made to ensure that the content of this publication is accurate but the publisher BBR VT International Ltd accepts no responsibility for effects arising there from. © BBR VT International Ltd 2017*

**BBR** A Global Network of Experts  
[www.bbrnetwork.com](http://www.bbrnetwork.com)